

TTC

SETUP SHEET

JMRC A All Japan
TRACK TC Championship

DATE 3-4.11.01

NAME Masami Hirosaka

FRONT

LENGTH
59.5mm

OUTER SPACER

PISTON
#3

INNER SPACER

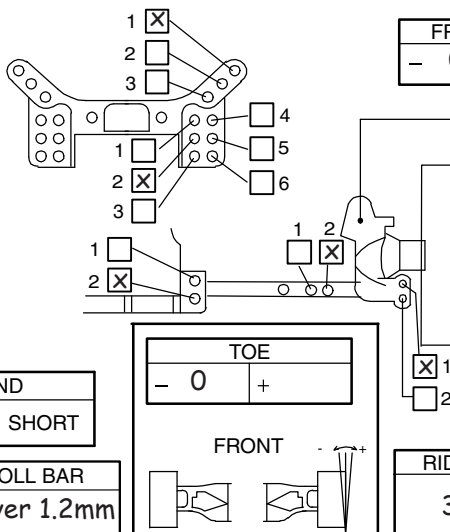
SPRING
GreenOIL
#350SHOCK END
LONG SHORTSHOCK
PLASTIC ALUMFRONT ROLL BAR
ZS-412F
ZS-412FW
ZS-412FSP
silver 1.2mmFRONT CAMBER
- 0 +CASTER BLOCK
STANDARD 5 DEG
TEAM SUZUKI 3 DEG
TEAM SUZUKI 5 DEG
TEAM SUZUKI 7 DEG
standard 3 degTIRE
Sorex
32R
INNER FOAM
Yokomo
ZR-039F (new)TOE
- 0 +

FRONT

RIDE HEIGHT
3.5 mm

PART DESCRIPTION	STANDARD	GRAPHITE
BULKHEAD		<input checked="" type="checkbox"/>
SHOCK TOWER		<input checked="" type="checkbox"/>
LOWER ARMS	<input checked="" type="checkbox"/>	
CASTER BLOCKS	<input checked="" type="checkbox"/>	
STEERING BLOCKS	see comment	

REAR

LENGTH
59.5mm

OUTER SPACER

PISTON
#3

INNER SPACER

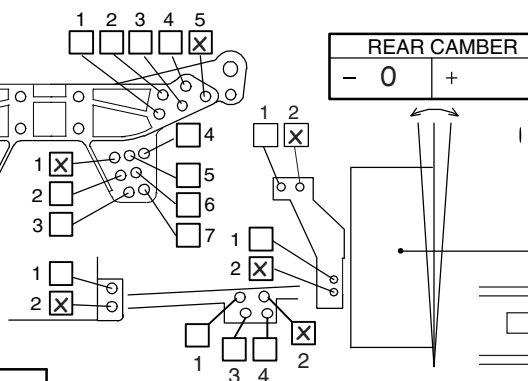
SPRING
GreenOIL
#350SHOCK END
LONG SHORTSHOCK
PLASTIC ALUMREAR ROLL BAR
 YES black 1.0mmTOE-IN BLOCKS
0 1 2REAR CAMBER
- 0 +

PART DESCRIPTION	STANDARD	GRAPHITE
BULKHEAD		<input checked="" type="checkbox"/>
SHOCK TOWER		<input checked="" type="checkbox"/>
LOWER ARMS	ZS-008 ZS-008RW	<input checked="" type="checkbox"/>

TIRE
Sorex
32R
INNER FOAM
Yokomo
ZR-039M (new)WHEELBASE
front 0.5 mm
rear 1.0 mm
RIDE HEIGHT
4.0 mm

CHASSIS	
<input checked="" type="checkbox"/>	GRAPHITE SLOTTED CHASSIS (TC SPECIAL)
	GRAPHITE SLOTTED CHASSIS (TC PRO)
	STANDARD SLOTTED CHASSIS

BODY
Yokomo Stratus new type CWING
Protoform StratusFRONT DRIVE
DIFF ONE-WAYCENTER DRIVE
DIRECT ONE-WAYSPEED CONTROL
GM V12XCSINGLE PIECE UPPER DECK
 STANDARD GRAPHITE
 MILLED FOR FLEXMOTOR
TYPE TURN / WIND
Reedy Ti 8x2GEAR RATIO
PINION SPUR
22 T 78 TBATTERIES
Yokomo Plus-8

TRACTION ADDITIVE

COMMENTS:

- new Yokomo Precision disk wheels used
- TQ and winner