

# SETUP SHEET

DATE 10.11.01

TRACK Blue Carpet race

NAME kentech

## FRONT

LENGTH	59.5mm
OUTER SPACER	
PISTON	#3
INNER SPACER	
SPRING	Green
OIL	40wt

SHOCK END		
LONG	X	SHORT

SHOCK		
PLASTIC	X	ALUM

FRONT ROLL BAR		
ZS-412F		
ZS-412FW		
ZS-412FSP	X	
1.2mm		

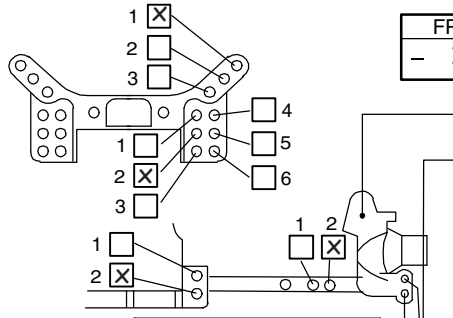

FRONT CAMBER		
-	1	+

CASTER BLOCK		
STANDARD 5 DEG		X
TEAM SUZUKI 3 DEG		
TEAM SUZUKI 5 DEG		
TEAM SUZUKI 7 DEG		

TIRE control	
TO SSA	

INNER FOAM	
037M	

TOE		
-	0	+

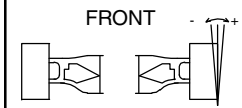

RIDE HEIGHT	
3.5 mm	

PART DESCRIPTION	STANDARD	GRAPHITE
BULKHEAD		X
SHOCK TOWER		X
LOWER ARMS	X	
CASTER BLOCKS	X	
STEERING BLOCKS	X	

## REAR

LENGTH	59.5mm
OUTER SPACER	
PISTON	#3
INNER SPACER	
SPRING	Green
OIL	40wt

SHOCK END		
LONG	X	SHORT

SHOCK		
PLASTIC	X	ALUM

REAR ROLL BAR		
YES		

TOE-IN BLOCKS		
0	1	2

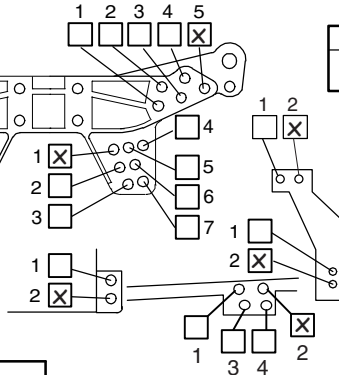

REAR CAMBER		
-	1	+

PART DESCRIPTION	STANDARD	GRAPHITE
BULKHEAD		X
SHOCK TOWER		X
LOWER ARMS	ZS-008	X
	ZS-008RW	

TIRE control	
SSA	

INNER FOAM	
037M	

WHEELBASE		
front	mm	
rear	mm	

RIDE HEIGHT	
4.0 mm	

CHASSIS	
X	GRAPHITE SLOTTED CHASSIS (TC SPECIAL)
	GRAPHITE SLOTTED CHASSIS (TC PRO)
	STANDARD SLOTTED CHASSIS

BODY	
Yokomo Stratus(ZR-YSB)	
WING	
Protoform Stratus	
FRONT DRIVE	
DIFF	X ONE-WAY
CENTER DRIVE	
DIRECT	X ONE-WAY
SPEED CONTROL	
LRP V7.1	

SINGLE PIECE UPPER DECK		
X	STANDARD	GRAPHITE
X	MILLED FOR FLEX	
MOTOR		
TYPE	TURN / WIND	
GEAR RATIO		
PINION	SPUR	
T	T	
BATTERIES		
TRACTION ADDITIVE		
LRP TopTraction		

COMMENTS:

- more consistent, better grip, with "old type" rear arms