

SETUP SHEET

DATE 07/2001

TRACK standard setup

NAME Masami Hirosaka

FRONT

LENGTH	59,7mm
OUTER SPACER	
PISTON	#3
INNER SPACER	
SPRING	yellow
OIL	400

SHOCK END		
LONG	X	SHORT

SHOCK		
PLASTIC	X	ALUM

FRONT ROLL BAR		
X	YES	1.2mm (upper)

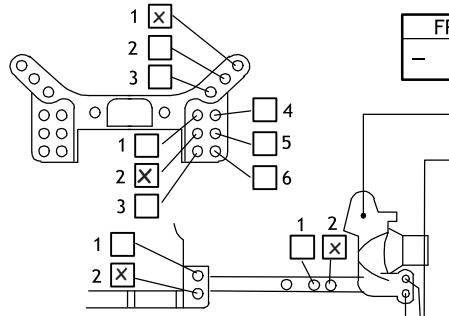

FRONT CAMBER	
-	+

CASTER BLOCK		
STANDARD 5 DEG		X
TEAM SUZUKI 3 DEG		
TEAM SUZUKI 5 DEG		
TEAM SUZUKI 7 DEG		

TIRE	INNER FOAM

TOE		
-	0	+

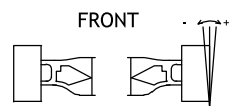

RIDE HEIGHT	
4.0	mm

PART DESCRIPTION	STANDARD	GRAPHITE
BULKHEAD		X
SHOCK TOWER		X
LOWER ARMS	X	
CASTER BLOCKS	X	
STEERING BLOCKS	X	

REAR

LENGTH	60.0mm
OUTER SPACER	
PISTON	#3
INNER SPACER	
SPRING	green
OIL	400

SHOCK END		
LONG	X	SHORT

SHOCK		
PLASTIC	X	ALUM

REAR ROLL BAR		
X	YES	

TOE-IN BLOCKS		
0	1	2

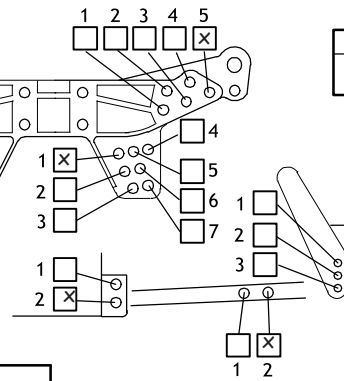

REAR CAMBER	
-	+

PART DESCRIPTION	STANDARD	GRAPHITE
BULKHEAD		X
SHOCK TOWER		X
LOWER ARMS	X	

TIRE	INNER FOAM

RIDE HEIGHT	
4.5	mm

CHASSIS		
	STANDARD CHASSIS (TC)	
X	GRAPHITE SLOTTED CHASSIS (TC PRO) SPECIAL	
	STANDARD SLOTTED CHASSIS (TC R)	

BODY	
Yokomo Stratus	

CENTER BRACE		
	STANDARD	GRAPHITE
X	SINGLE PIECE UPPER DECK	

WING	
Yokomo 180mm	

MOTOR	
TURN	WIND

FRONT DRIVE		
DIFF	X	ONE-WAY

GEAR RATIO		
PINION		SPUR
T		T

CENTER DRIVE		
DIRECT	X	ONE-WAY

BATTERIES	
-----------	--

SPEED CONTROL	
GM V12 XC	

TRACTION ADDITIVE	
-------------------	--

COMMENTS:

- milled upper deck
- servo mounted horizontally
- new rear arms used (ZS-008RW)